

**// OPERATION MANUAL**

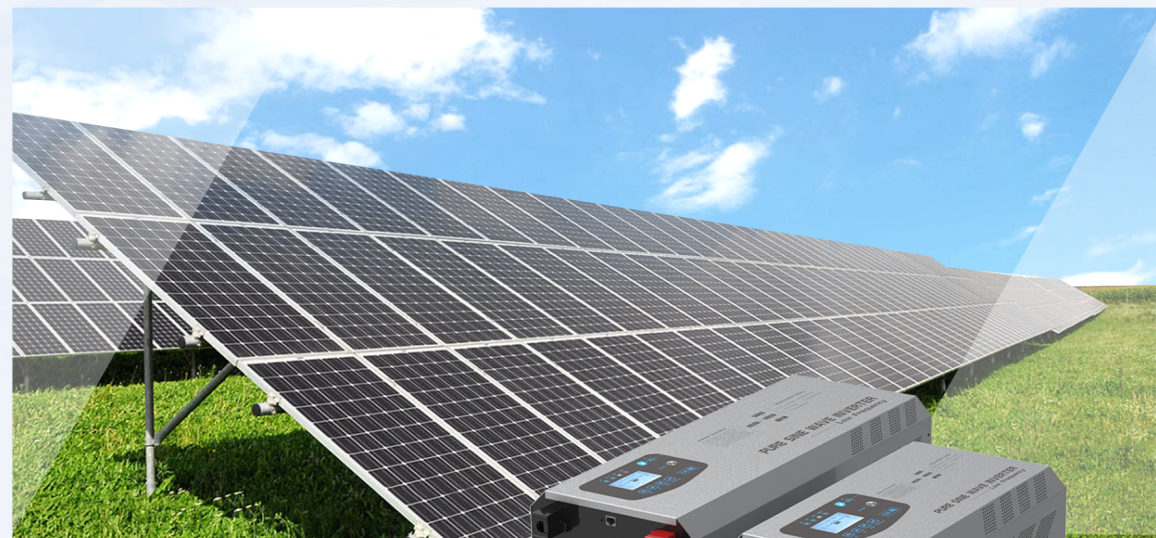

**PURE SINE WAVE INVERTER**

**———— Low Frequency**

## Safety Precautions

### Operational Safety

1. Please read "Safety Precautions" carefully before using this product to ensure correct and safe use. Please keep this manual in a safe place.
2. When operating, please pay attention to all warning signs and operate as required.
3. Do not use the device in direct sunlight, rain or moisture environment.
4. This equipment cannot be installed near heat source areas, or near electric heaters, furnaces, etc.
5. When placing the inverter, keep a safe distance around it, ensure ventilation and heat dissipation and product maintenance. Please refer to this manual when installing.
6. When cleaning, use a dry, non-conductive item to wipe.
7. In the event of a fire, please use a dry power fire extinguisher for fire fighting. Do not use liquid fire extinguishers.
8. Please consider the floor-to-machine and battery pack load-bearing capabilities before installation.
9. Before using the device, please ensure that the load power matches the rated power of the inverter and the battery specifications.

### Prohibited Matter

1. There is high voltage inside the power supply equipment, not the company or a technician who is not authorized by the company, Do not open the lid without authorization, otherwise there is a danger of electric shock and loss of warranty.
2. Before applying to the following load equipment, please discuss with the dealer in advance; its application, setup, management and maintenance must have special considerations and design:
  - A. Precision industrial, scientific and medical instruments and equipment;
  - B. Elevators and other equipment that may endanger personal safety;
  - C. Starting a load device with a large current and generating negative work;
3. Do not place the battery in a fire to avoid explosion.

### Electrical Safety

1. Before powering up, please confirm that it is properly grounded and check the correctness of the distribution line and battery polarity.
2. The battery protection device must be equipped with an overcurrent protection circuit breaker of the rated specification.
3. When the inverter needs to be moved or re-wired, it must be ensured that the inverter is completely shut down and the input breaker and battery switch are disconnected, otherwise the output may still be charged and there is a danger of electric shock.
4. Before connecting the inverter, the client must install a four-pole overcurrent protection device with rated value in the power distribution system to disconnect all input lines to prevent electric shock.

## Battery Safety

1. The life of the battery is shortened as the ambient temperature increases. Regular battery replacement ensures that the inverter is working properly and that sufficient backup time is guaranteed.
2. Battery replacement and maintenance should only be carried out by authorized personnel with battery expertise. The same type and model of battery must be used and must be the same quantity.
3. There is a danger of electric shock and short current in the battery. To avoid electric shock and injury, please observe the following warnings when replacing the battery:
  - A. Do not wear watches, rings or similar metal objects;
  - B. Use insulated tools;
  - C. Wear rubber shoes and gloves;
  - D. Do not place metal tools or similar metal parts on the battery;
  - E. Disconnect the load connected to the battery before removing the battery connection terminal.
4. It is strictly forbidden to expose the battery to fire to avoid explosion and endanger personal safety.
5. Non-professionals should not open or damage the battery, because the electrolyte in the battery contains dangerous substances such as strong acid, which can cause damage to the skin and eyes. If you accidentally come into contact with the electrolyte, immediately wash it with plenty of water and go to the hospital for examination.
6. Do not short-circuit the positive and negative terminals of the battery. Over-current protection must be installed in the battery box to prevent fire or electric shock.

## Use And Maintenance

1. The use environment and storage methods have an impact on the service life and reliability of this product. Therefore, please be careful not to use it in the following working environments:
  - A. High, low temperature and humidity places that exceed the technical specifications (temperature 0-40 °C, relative humidity 0-95%);
  - B. Locations that are subject to vibration and are subject to collision;
  - C. Locations with metallic dust, corrosive substances, salt and flammable gases.
2. If not used for a long time, the inverter (without battery) must be stored in a dry environment with a storage temperature range of -25-55 °C. Before the inverter is turned on, the ambient temperature must be warmed to above 0 °C for more than 2 hours.
3. Please keep the inlet and exhaust holes open. Poor ventilation of the inlet and exhaust holes can cause the temperature inside the inverter to rise, shortening the life of components in the machine, which will affect the life of the machine.
4. When the battery is not used for a long time at normal temperature, the battery needs to be charged once for three consecutive months; in high temperature environment, it needs to be charged once for two months without charging, no less than 10 hours each time; For discharge, the battery should last for no more than 14 hours.

# Catalogue

---

Inverter appearance	01
LCD panel description	02
Unpacking inspection	03
Installation notes	03
Inverter installation circuit diagram	04
Inverter operation instructions	06
Resolve fault	11
Maintenance and cleaning	12
Technical data sheet	13

## 1. Inverter appearance

### 1.1. 1000W/2000W/3000W appearance

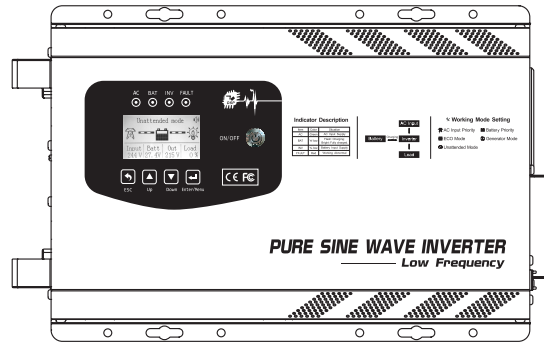

### 1.2. 4000W/5000W/6000W appearance

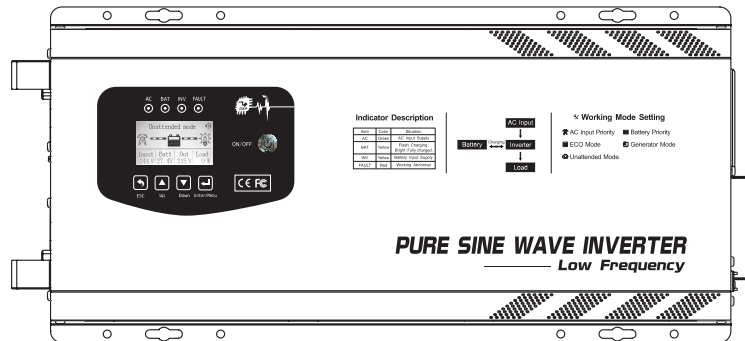

### 1.3. Dimension

Model	FT-Series 1KW-3KW	FT-Series 4KW-6KW
Dimension	L*W*H 475X300X185mm	L*W*H 650X300X185mm

## 2. LCD panel description

LCD screen is an interface used for man-machine interaction, which can be used for visual operation through LCD screen, which provides a friendly interface for functions such as turn on, turn off, state display, fault alarm, parameter setting, and so on. After installation, the user can complete all operations through the LCD screen. The LCD screen includes three parts: status indicator, LCD display screen, and navigation key. The following table describes the status indicator and the navigation button respectively.

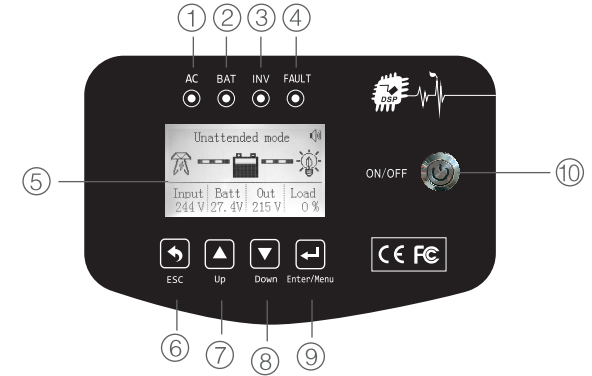

#### • Status Indicator

Identification	Indicator light name	Status
①	AC	AC Normal
②	Battery	Flash: Charging; long bright: full
③	Inverter	Battery inverter power supply
④	Fault	Warning/work abnormal

#### • LCD Display——⑤: Detailed display information

• Navigation keys: selection, opening, obtaining information, modifying system parameters, etc.

Identification	Navigation keys	Name	Function
⑥	↶	Return	Return to the previous interface menu or exit the settings interface (do not save the settings)
⑦	▲	UP	Page turning; switching options; adding settings value
⑧	▼	Down	Page turning; switching options; minus setting values
⑨	↵	Confirm	Press and hold for 5 seconds to enter the setting interface; short press to confirm the saving settings to enter the setting submenu
⑩	⏻	Turn On/Off	Turn on and shutdown operation

### 3. Unpacking inspection

1. Open the Package ,it should include:

- 1) One unit Inverter
- 2) Communication Wire(optional)
- 3) External display (optional)
- 4) User manual

2. Check if the inverter is damaged during transportation. If damage is found or parts are missing, do not turn it on. Contact the carrier or dealer immediately.

Note: Confirm the height of the door and other obstacles in the channel before handling.

### 4. Installation Notes

1. Installation of the FT Series must be performed by personnel with electrical safety knowledge.

The installation space is shown in the figure below:

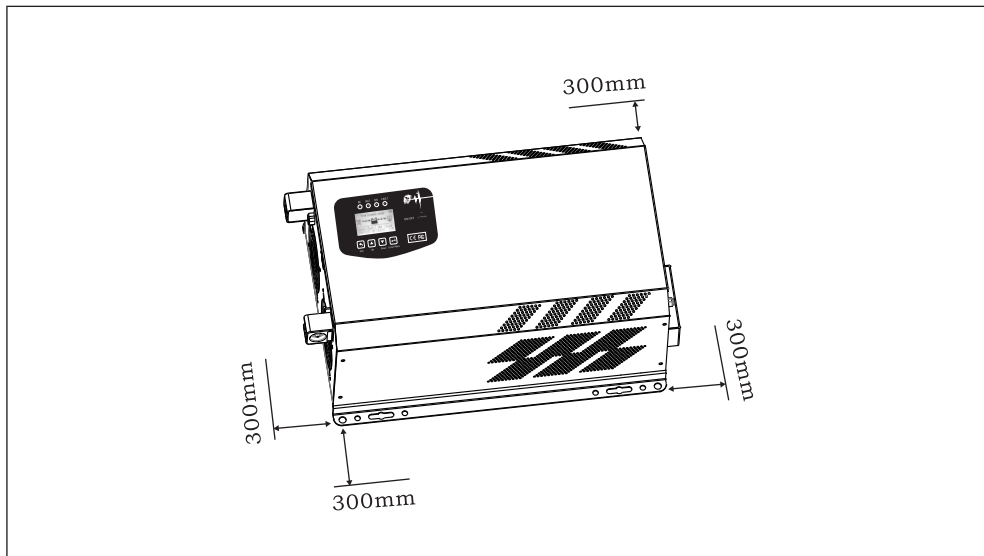

### 5. Inverter installation circuit diagram

The inverter with higher power is connected to the AC input and the load output through the terminal block, and the load output is used in addition to the terminal. Row mode output, also provides socket output

(Note: the output socket must not exceed 2KW<10A)

#### 5.1. AC input and output load connection

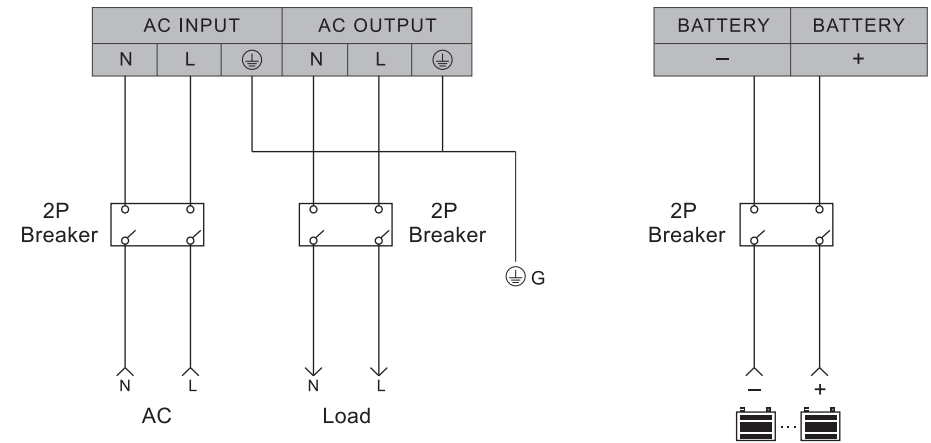

#### 5.2. Battery connection



Pay attention to the positive and negative polarity of the battery, prohibit reverse connection and damage.

#### 12V series battery wiring diagram

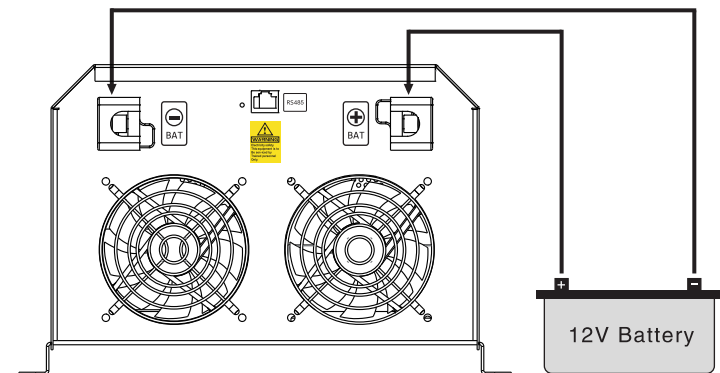

## 5. Inverter installation circuit diagram

### 5.3. Battery connection

24V series battery wiring diagram

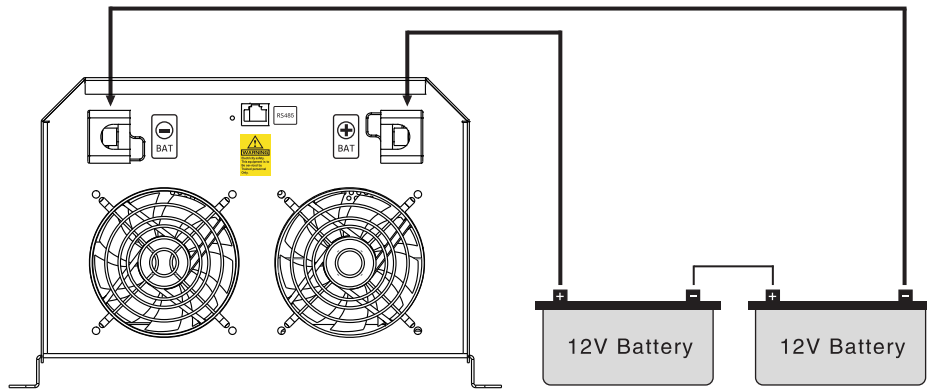

### 5.4. Battery connection

48V series battery wiring diagram

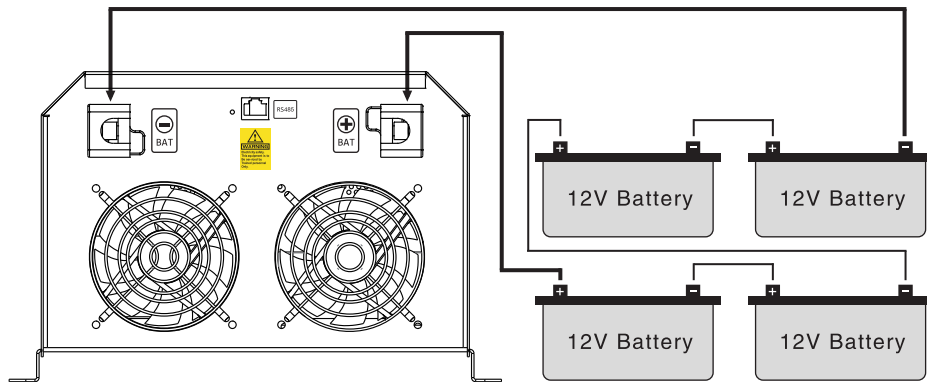

## 5. Inverter installation circuit diagram

### 5.5. Battery connection

96V series battery wiring diagram

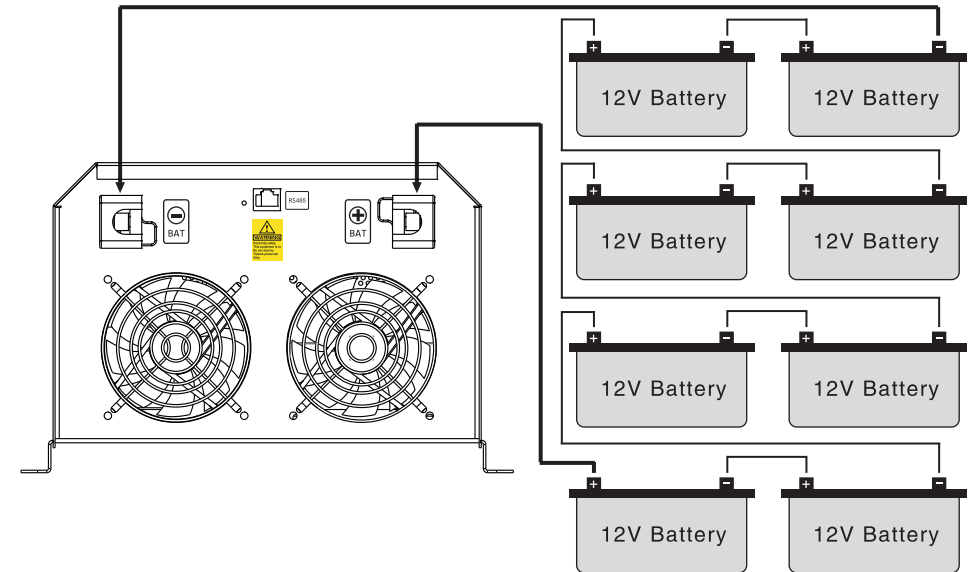

## 6. Inverter operation instructions

### 6.1. The main interface description is as shown

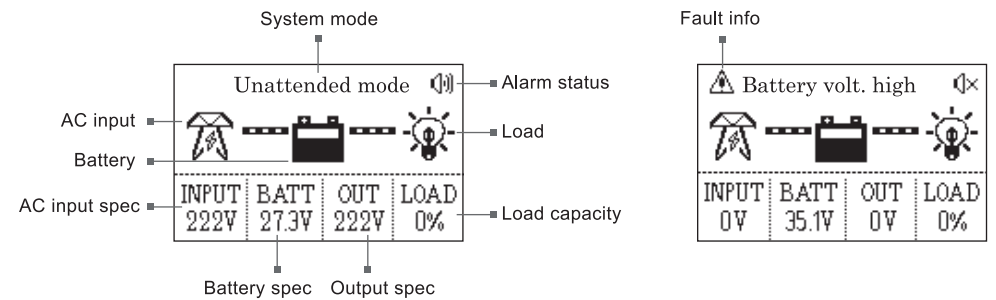

## 6. Inverter operation instructions

6.2. In the unattended mode, the battery voltage will be too low to enter the system standby.

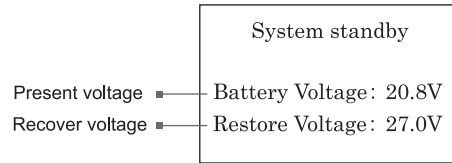

6.3. In the default main interface, press the up (▲) or down (▼) button to scroll through the pages. Under the main page, long press the back and down keys to restore the factory settings.

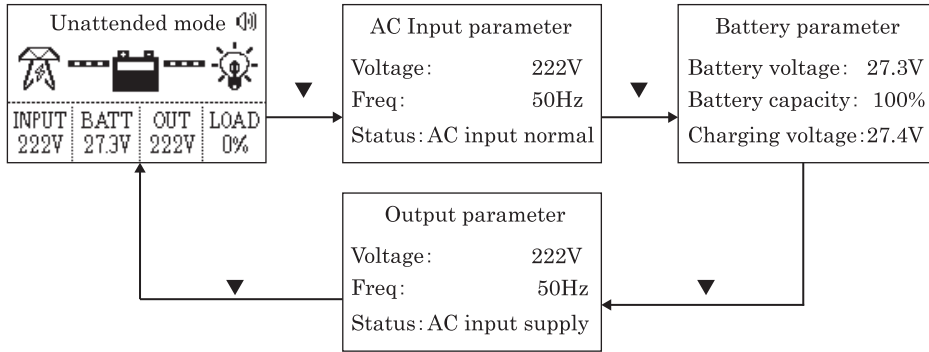

6.4. In the default main interface, long press the confirm (↵) button for five seconds to enter the setup menu, press the (▼) button to scroll through the submenus. Set to battery priority mode, the default charge is off, you need to charge to the current settings page.

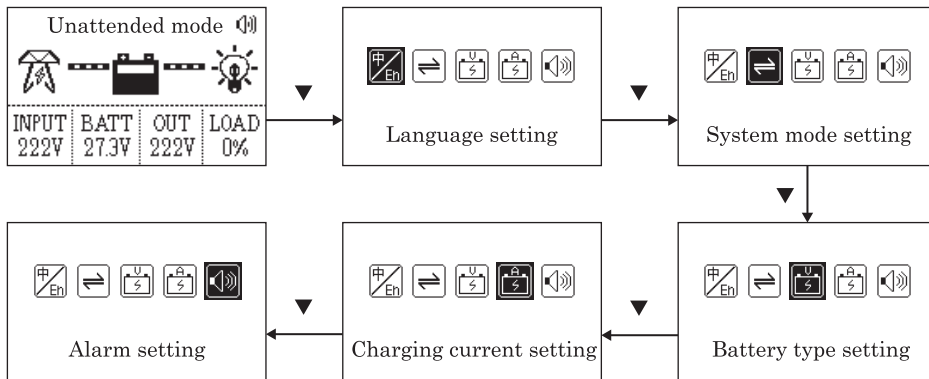

## 6. Inverter operation instructions

6.5. Language setting

In the default main interface, long press the confirm (↵) button for five seconds to enter the setup menu, press the (▼) button to select the language setting and press the confirm (↵) button to confirm, press the return (↩) button to return to the menu or wait after the pop-up is successful. 2 seconds automatically returns to the menu.

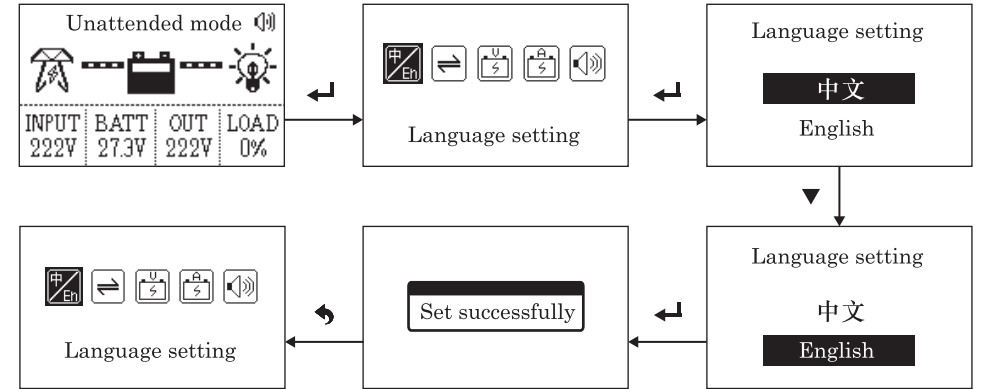

6.6. Charging current setting

In the default main interface, long press the confirm (↵) button for five seconds to enter the setup menu, press the (▼) button to select the charging current setting and press the confirm (↵) button to confirm, press the (▼) button to modify the value, confirm the value and press to confirm (↵) button, press the return (↩) button to return to the menu after the pop-up setting is successful or wait for 2 seconds to automatically return to the menu.

(Note: setting the value to 0% will turn off the charging function)

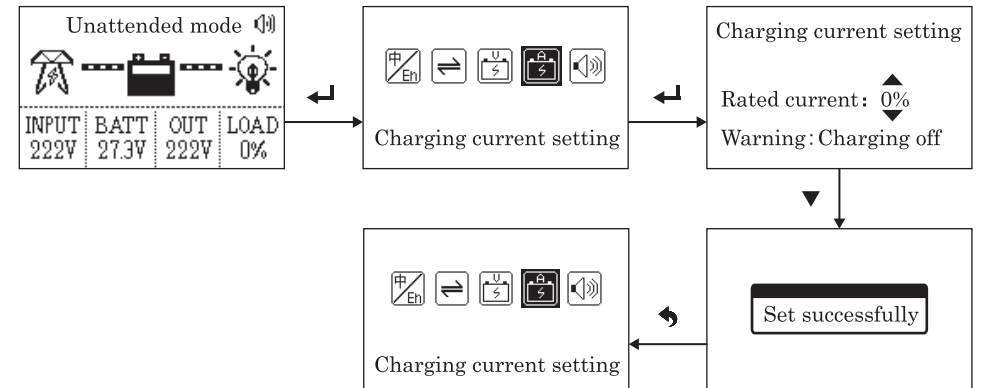

## 6. Inverter operation instructions

### 6.7. System mode setting

In the default main interface, long press the confirm (↵) button for five seconds to enter the setup menu, press the (▼) button to select the system mode setting and press the confirm (↵) button to confirm, enter the mode selection press (▼) button to select the option, pop-up settings After success, press the Back (←) button to return to the menu or wait for 2 seconds to automatically return to the menu.

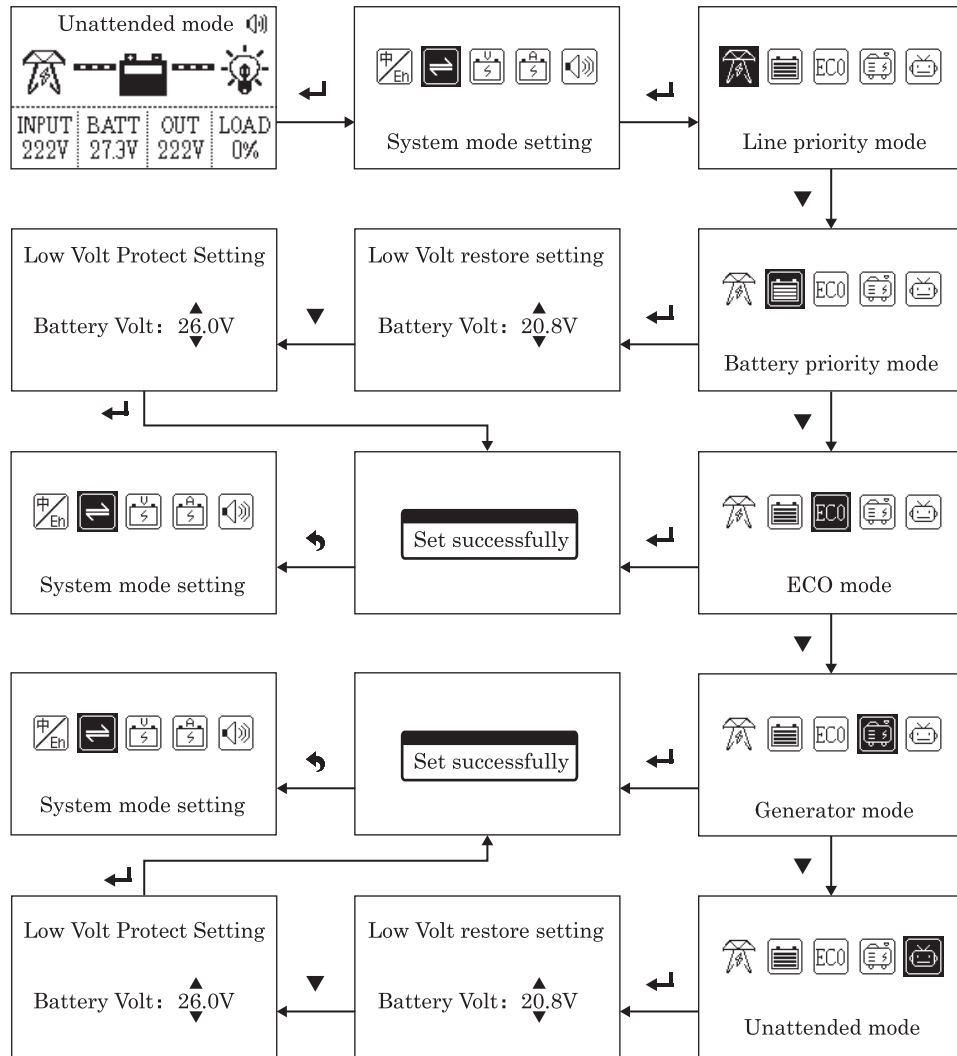

## 6. Inverter operation instructions

### 6.8. Battery type setting



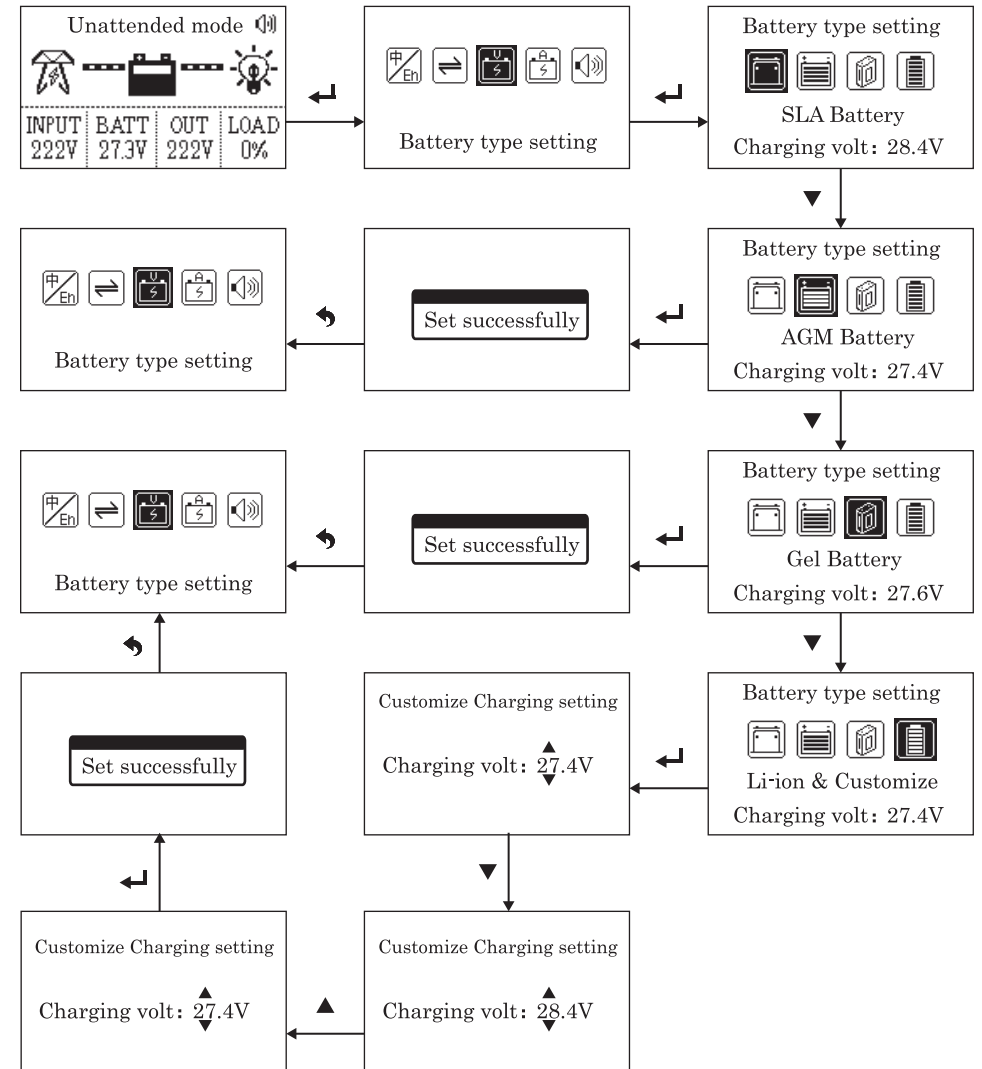

In the default main interface, the long press confirm (↵) key 5 seconds into the settings menu, press (▼) button to select battery type settings and then press confirm (↵) key confirmation, enter mode select press (▼) key selection option, Press return (←) to return to menu or wait for 2 seconds to automatically return to menu.





## 6. Inverter operation instructions

### 6.9. Alarm setting

In the default main interface, long press the confirm (  ) button for five seconds to enter the setup menu, press the (  ) button to select the alarm tone setting and press the confirm (  ) button to confirm, press the return (  ) button to return to the menu or Wait 2 seconds to automatically return to the menu.

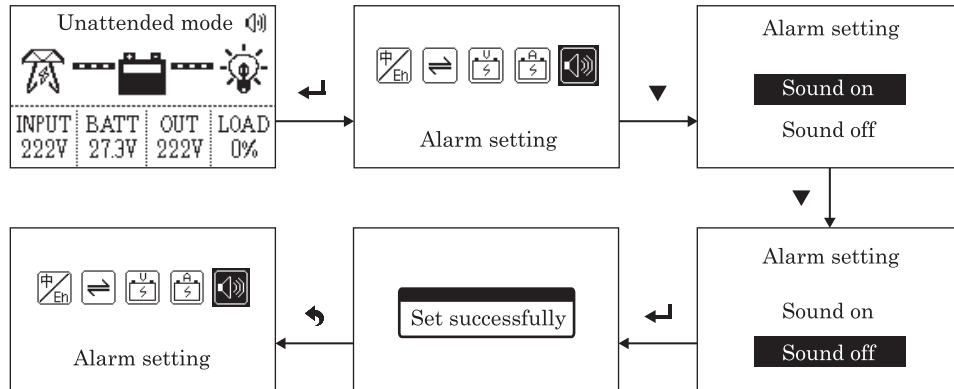

## 7. Resolve Fault

Fault	Reason	Resolution
No AC input	Resettable fuse pops up	Press the eject button again
Battery terminal heat	Poor contact or loose	Screw tightly again
Short down with load	Battery is finished and overload	Charge battery or reduce load
Can't turn on	AC input or battery cable is not connected	Check if the battery cable is connected or reconnected
Turn on alarm	Battery without electricity or over loaded	Charge battery or reduce some load
The buzzer is called 2 seconds to stop for 1 second	Over temp. alarm( 85°C alarm-90°C short down)	Check if the fan and cooling holes are blocked
The fan rotates sometimes fast and sometimes slow	The temperature inside the machine reaches 45 degrees fast and 42 degrees slow.	Normal phenomenon, the fan is an intelligent control method

## 8. Maintenance and cleaning

1. This series of inverters requires very little maintenance. The standard model battery is valve-regulated, low-maintenance, and requires constant charging to achieve the desired life. When the inverter is connected to the AC input, it always charges the battery regardless of whether it is turned on or off, and provides overcharge and overdischarge protection.
2. If the inverter is not used for a long time, it is recommended to charge battery every four to six months.
3. Normally, the battery life is three to five years, if it is found to be in poor condition, it must be replaced early. When replacing the battery, it must be handled by a professional.
4. The battery should not be replaced individually. Please replace all batteries to ensure the backup time of the inverter.
5. Normally, the battery is charged and discharged every four to six months, and charged after being discharged to the shutdown, and the standard charging time must not be less than 12 hours.
6. In high temperature areas, the battery is charged and discharged every two months, and the charging time must not be less than 12 hours.

Note:

- ★ Before replacing the battery, the inverter must be turned off and off the AC input, and the battery switch should be turned off.
- ★ Take off metal items such as rings and watches.
- ★ Use insulated handles and screwdrivers, and do not place tools or other metal objects on the battery.
- ★ When connecting the battery cable, it is normal for a small spark to appear at the joint, which will not cause harm to personal safety and the inverter.
- ★ Never short or reverse the battery.

If you connect the generator, you need to follow the steps as below:

- ★ Start the generator, after the operation is stable, connect the output power of the generator to the input of the inverter (at this time, make sure that the inverter is no-load), and then start the inverter according to the startup process. After the inverter is started, connect the load one by one.
- ★ It is recommended to select the generator capacity two to three times the capacity of the inverter.

## 9. Technical Data Sheet

Model	FT-102	FT-202	FT-302	FT-402	FT-502	FT-602
Rated Power	1000W	2000W	3000W	4000W	5000W	6000W
Input	Voltage (170-265) VAC					
	Frequency 45-65Hz					
Output	Voltage AC230V±3% (Battery Mode)					
	Frequency ±0.5Hz (Battery Mode)					
Output wave form	Pure Sine Wave					
Overall efficiency	>90%					
Battery Form	Optional battery type (optional)					
Battery Rated Voltage	12/24/48VDC			24/48/96VDC		
Ac maximum charge current	0-35A(Optional) (96V maximum 15A)					
Protection	Overload, short circuit, battery high voltage and low voltage protection High voltage and low voltage protection					
Conversion mode	Online interactive					
Overload capacity	110%-120% of the output was maintained for 30 seconds, then the output turned to bypass, and more than 160% maintained the 300ms.					
Communication interface	RS-485					
Work environment	Temperature -20~+75°C					
	Humidity 10%~90%					
Size L*W*H	475X300X185mm			650X300X185mm		
N.W/G.W(kg)	12.7Kg	15.5Kg	17Kg	22.9Kg	25.4Kg	30.4Kg