

MPPT

SOLAR CHARGE CONTROLLER

COLOR OPTIONAL



50A/60A/80A/100A/120A Series

Thank you very much for choosing MPPT controller. The new generation MPPT we produce, is the brand new product developed based on the newest technology which represents the newest high-level photovoltaic development. Excellent performances are listed as below:

- Excellent heat dissipation design and cooling fan of intelligent control;
- Creative maximum power point tracking technology can significantly increase the energy utilization rate of the solar system and can reach transfer efficiency of 97%;
- Quickly scan the entire I-V curve; track the maximum power point within several seconds;
- Three types of lead-acid batteries include sealing, colloid and open and lithium battery series charging program can be selected;
- Controller protection function: over charge, over discharge, over-load, short circuit self-protection;
- Rs485 communication interface realizes multi-machine communication with communication distance of 1km and communication with host computer which enables you to check operating parameters of controller conveniently.

The controller is used in solar off-grid system (independent system) which automatically switches to the mode of charge or discharge. MPPT controller has an advanced tracking algorithm to obtain the maximum power of the solar cell module so as to charge battery; at the same time, its low-voltage disconnect (LVD) function can prevent the damage caused by over-discharge of the battery. The charging process of MPPT controller's battery is optimized which can extend battery life and improve system performance. Its comprehensive self-test function and electronic protection function can avoid damage caused by installation error and system fault. Although the TY-series MPPT controller is easy to operate and use, it would be better for you to take some time to learn the instructions and specification of this manual in order to use all the functions better improve your PV system.

The features of the maximum power point tracking technology

The Mp-series MPPT controller utilizes maximum power point tracking technology to extract the maximum power from the solar array to charge the battery. The maximum power point tracking mode is fully automatic and does not require user to adjust. When the maximum power point of the array changes with ambient conditions, the controller automatically tracks the maximum power point of the array to ensure that the maximum energy of the day is obtained from the solar array.

● Increase current

In most cases, the maximum power point tracking technique will "increase" the charge current of the solar system. Assuming that a system may have 10 amps of current flowing from the solar array into the MPPT controller and 12 amps of current flowing from the MPPT controller into battery.

MPPT controller does not generate current! The energy input to the MPPT controller is equal to its output energy. Since the power is the product of voltage and current (volts x amperes), the following situations are true:

- (1) MPPT controller input energy = MPPT controller output energy
- (2) Input voltage x Input current = Output voltage x Output current

* Assume that the efficiency is 100% and ignore the power loss caused by wire and conversion. If the maximum power point voltage V_{mp} of the solar array is larger than the battery voltage, the battery charge current must be proportionally larger than the solar array output current so that the input and output power can be balanced. The greater the difference between the V_{mp} voltage and the battery voltage, the greater the current boost. Current boost is extremely important in the system because the maximum power point voltage V_{mp} voltage of the solar panel in the solar power system is usually higher than the battery voltage.

- The advanced condition compared with traditional controller.

The traditional controller directly connects the solar array to the battery when charging. It requires the solar array to operate normally below the V_{mp} voltage range. Take 12V system as an example. The range of battery voltage is usually 11-15V, but the V_{mp} voltage of solar array is usually about 16 or 17V.

The diagram below shows curve of current, voltage and output power of off-grid solar battery of typical nominal rated voltage 12V .

Current and voltage of 12V solar battery

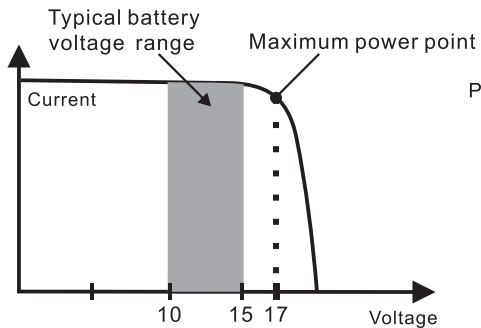

Output power of 12V solar battery

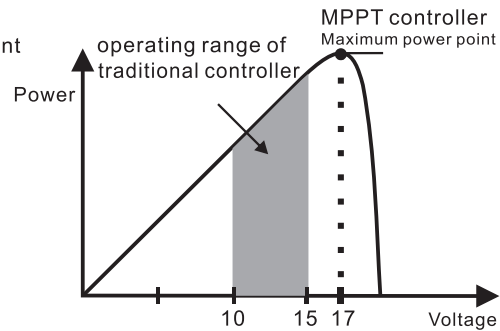

Nominal 12V solar cell I-V curve and output power diagram

Maximum power point voltage V_{mp} of solar PV array is the voltage of maximum output power (Amp x Volts), which is showed in the "knee" of the left diagram of above, the solar PV array I-V curve.

Since the conventional controller does not always operate in the solar PV array V_{mp} , the energy is wasted which originally can be used to charge battery and supply power to the system load. The greater the difference between the battery voltage and the V_{mp} of the solar PV array, the more energy will be wasted. The MPPT controller will always operate at the maximum power point which reduces energy waste compared with conventional controllers.

- The limiting factor of the maximum power point tracking controller:

The V_{mp} of the solar PV array will decrease as the temperature of the array increases. In hot weather, V_{mp} may be close to or even lower than the battery voltage. In this case, the MPPT controller will have little or no access to energy compared with conventional controllers. However, as long as the nominal voltage of the system PV module is higher than the battery voltage, the V_{mp} of the PV module will be always higher than the battery voltage. In addition, decrease of the current of the solar array saves wires which enables the MPPT controller also has obvious advantages even in hot weather.

CONTENT

1. Precautions	01
2. Safety instructions	01
2.1 Safety precautions	01
2.2 Logo description	02
2.3 Safety instructions	02
3. Inspection of equipment opening seal	03
4. Controller installation	03
4.1 Selection of installation position	03
5. MPPT controller connection	04
5.1 Combination of Solar Charging System	05
5.2 Wiring	05
5.3 Power trial run	07
6. MPPT controller operation instruction	08
6.1 Panel part specification	08
6.2 Indicator light state description	08
6.3 LCD Display instruction	09
6.4 Parameter setting	12
7. Technical parameter	20
8. Maintenance & cleaning	25
9. Fault elimination	25
10. Quality assurance	26

This manual describes the operation related to the MPPT solar charge controller.

1.1 Effectiveness

This manual is applicable to all models of MPPT solar charge controller of our company



1.2 Target groups

This manual applies to installers and operators

1.3 Before installing and operating the controller, please read this manual and keep it carefully.



1.4 Symbol Description

The followings are descriptions of the type of logo that appears in this manual:

	Warning ! If not avoided, it may cause a machine stoppage or accident
	Danger ! If not avoided, it may cause a machine stoppage or accident
	Attention ! In order to operate the equipment effectively, please read the equipment operation instructions carefully



2. Safety Precautions

2.1 Safety Precautions

	Warning ! <ul style="list-style-type: none"> • Input voltage range of this controller is large. It will lead to personal injuries if it is not operated cautiously; • All work on the charge controller must be carried out by a technician; • The device can not be operated by children or people lack of body sensibility and those who are poor in their minds, lack of experience and knowledge of the operation; • Keep away from children and make sure children can not touch.
	Warning ! High heat housing parts. <ul style="list-style-type: none"> • Please install in a well ventilated environment.
	Warning ! Radiation is harmful to healthy <ul style="list-style-type: none"> • Do not stay near the solar charger controller within 20 cm for a long time.



2.2 Logo Description

This section shows all instructions displayed on all device labels.

Logo	Instruction
	Risk of electric shock ; The energy stored in the capacitor will remain after five minutes of disconnection, and after the break, do not touch internal components within 5 minutes.
	There is not self-repair parts inside the machine, so do not try to remove the cover; only professional personnel can operate and maintain the equipment; please use the insulation tool to drop risk of harm during operation.
	Beware of high heat shell ; The solar charger controller becomes hot during operation. Avoid contact during operation; It is forbidden to place any items on the equipment and to block the fan vents.

2.3 Safety instructions

- When using this equipment, please keep the following information in mind so as to avoid fire, lightning or other personal injuries :

	Warning ! Make sure that the input DC voltage = the specified maximum voltage, the voltage is too high may cause permanent, Damage to the solar controller, the above situation will not be included in the warranty period. This chapter contains important safety and operating instructions. Read and keep this manual for future use.
	Warning ! The technician if you want to maintain or clean the solar controller or connect to the circuit, must first follow the relevant steps.

- Before using the solar charge controller, read all instructions and warning signs on the solar charge controller and the corresponding sections of this manual;
- Please use the parts recommended or sold by our company;
- Make sure the existing lines are in good conditions and wire size are suitable in order to avoid the risk of fire and electric shock; do not operate when solar controller is damaged and wiring is qualified;
- Do not disassemble the solar charge controller by yourself. Attempts to repair a solar charge controller may result in further risk of damage or accident and loss of quality of warranty;
- Keep away from flammable and explosive materials in order to avoid fire;
- The installation location should be kept away from moisture or corrosive substances;
- In order to reduce the rate of short circuit, the technician must use the insulation tool to operate the equipment.

3. Inspection of equipment opening sealing

3.1 The following accessories are included after purchasing the equipment

Item	Quantity	Remark
Controller	1	
Temperature sensor	1	
Operation Manual	1	

Please contact distributor when finding missing parts.

3.2 Check if it is damaged during transportation

After receiving device, please do not rush to sign at first, please open the sealing and check whether there is damage or crack appearance, if there is, please refuse to sign and contact distributor.



3.3 Confirm charging controller

The label of charging controller is pasted on the side of case, If you find the device does not matched the one you purchase, please contact distributor.

4. Controller Installation

Installation must be done by professional technician.

4.1 Selection of installation position

	<p>Danger: The case of charging controller will become hot during operation.</p> <ul style="list-style-type: none"> Do not install on the flammable building material; Do not install nearby the highly flammable material; Do not install in the potentially dangerous explosion area; Do not install the charging controller in direct sunlight in order to avoid the loss caused by overheating.
	<p>Warning: The controller has built-in thermal storage module components.</p> <ul style="list-style-type: none"> Do not touch the controller while it is working and the case is open.

4.1.1 Size

Model	50A/60A Series	80A Series	100A/120A Series
Size	230 x 279 x 91mm	230 x 304 x 91mm	303 x 436 x 138mm

4. Controller Installation

4.1.2 Environment Condition

- Install on solid surface;
- Installation position must be approachable anytime;
- Installation position can be removed anytime;
- Only temperature of -20°C~50°C can confirm the best working environment;
- Do not install the charging controller in direct sunlight in order to avoid power damage caused by overheating.

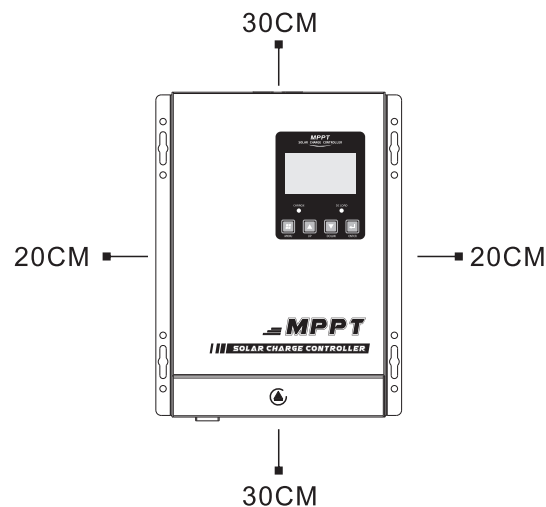

4.1.3 Safety Distance

Observe the following safety gap, make sure other equipment or object are not in this range and make sure there is enough room for heat dissipation.



Instruction	Safety Distance
Edge	20CM
Height	20CM
Bottom	30CM

5. MPPT Controller Connection

	<p>Danger ! If it is input high voltage and operation is not correct, solar charger controller may lead to life-threatening.</p> <ul style="list-style-type: none"> Disconnecting the solar panels should use a circuit breaker and avoid accidental activation. Disconnect the circuit breaker and make sure it can not be connected again; Make sure there is no voltage in system.
	<p>Warning ! Over-voltage can damage system</p> <ul style="list-style-type: none"> Thunderstorms and lightning will increase the risk of damage to external over-voltage protection areas.

5. MPPT Controller Connection

5.1 Combination of Solar Charging System

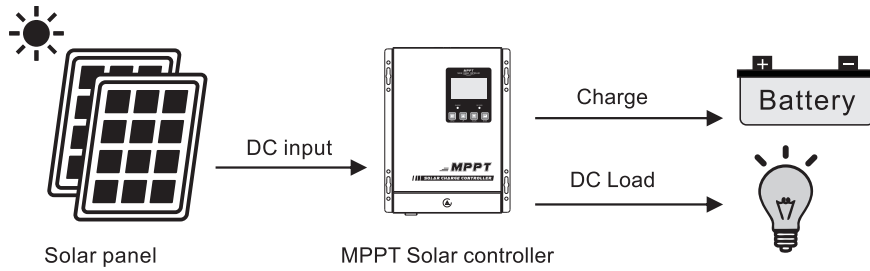

5.2 Wiring

5.2.1 Wiring Steps

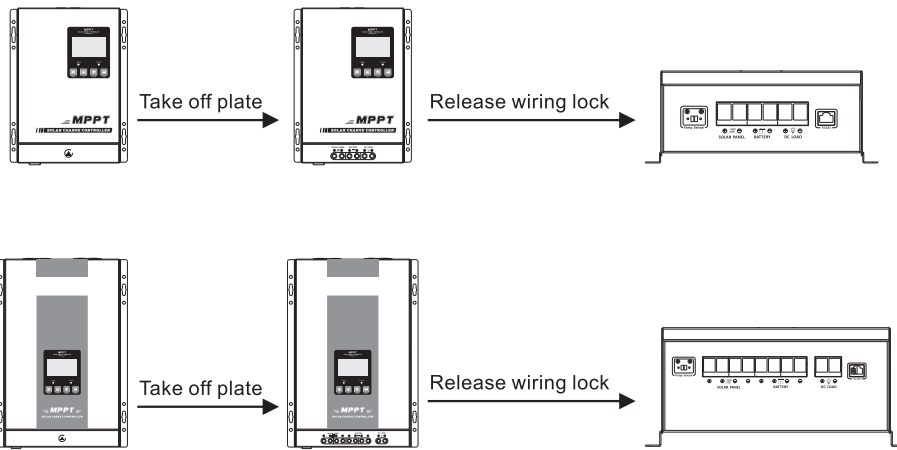

Specifications of cable and miniature circuit breaker:

Model	50A	60A	80A	100A	120A
Cable (copper)	10mm ²	16mm ²	16mm ²	25mm ²	25mm ²
Circuit Breaker	63A	100A	100A	125A	125A

5. MPPT Controller Connection

5.2.2 Battery Connection



Warning: Short circuit of battery's positive and negative terminals and wires of positive and negative electrode will lead to fire or risk of explosion. Please operate carefully.

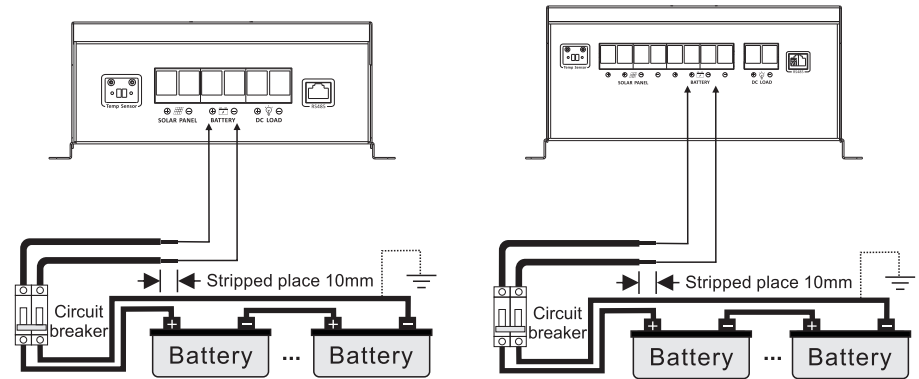

Attention: The operation of connecting batteries must be done under the situation that the circuit breaker is disconnected.

5.2.3 DC Load Connection

Controller "DC LOAD" side can be connected to the DC power equipment whose rated operating voltage is same with battery's rated voltage. The controller supplies electricity with battery voltage.

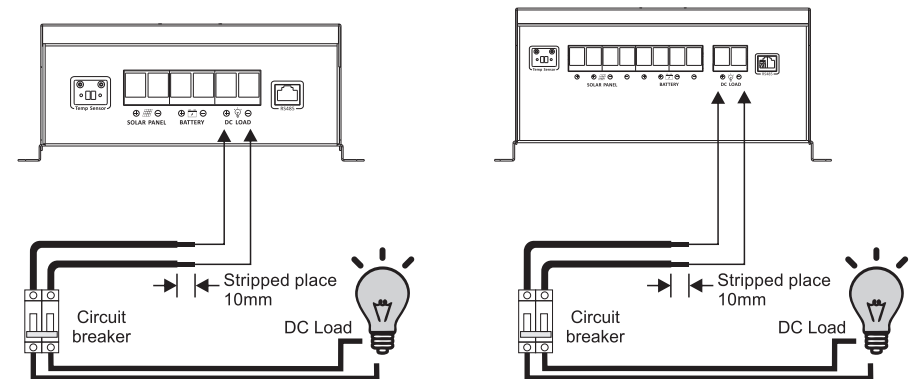

5. MPPT Controller Connection

5.2.4 Photovoltaic component connection



Warning: Electric shock danger! Photovoltaic component may produce very high voltage, so be careful electric shock when wiring.

Controller can match 12V, 24V, 36V, 48V, 96V off-grid system solar component, it's also can use a grid-connected component that open-circuit voltage does not exceed the specified maximum input voltage. The solar component voltage in the system must be not lower than the system voltage.

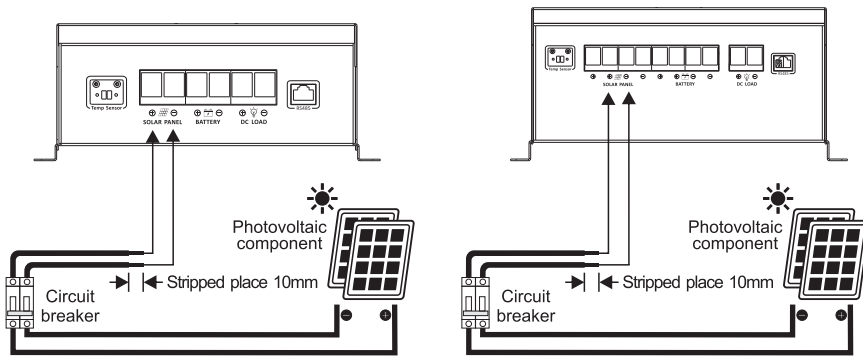

Attention: The operation of connecting photovoltaic component must be done under the situation that the circuit breaker is disconnected.

5.3 Power trial run



Attention: please make sure that all the positive and negative poles of the DC connection are connected correctly before the trial run

Proceed as the followings :

1. Make sure that the positive and negative terminals of the cable are fully connected and measure if the open circuit voltage of the PV module is within the operating range of the controller;
2. Turn on the circuit breaker connected with controller and battery;
3. Turn on the circuit breaker connected with controller and solar panel;
4. Then the controller starts to enter the self-test mode; if system conditions are correct, the controller automatically enter the working mode; If the system conditions are not correct, the controller will have fault indications, refer to the chapter of fault elimination.
5. Battery type: the factory setting defaults lead-acid maintenance-free battery, refer to the battery type settings.

6. Operating Instruction of MPPT Controller

6.1 Panel part specification

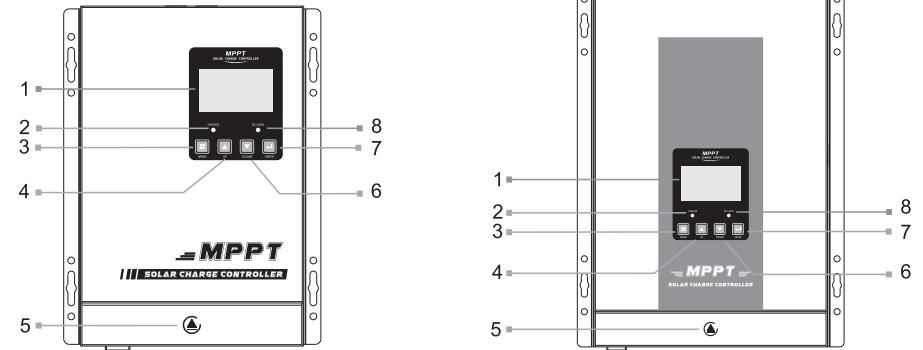

No	Name	No	Name
1	LCD Display	5	Wiring Plate
2	Charging indicator light	6	Down
3	Function Menu	7	Enter
4	Up	8	DC Load indicator light

6.2 Indicator Light State Description

Name	State	Description
Charging indication	Flashing	Maximum power tracking mode charging
	Low Flashing	Float charging mode
	Putout	Stop charging
DC Load indicator light	Lighting	Normal output
	Flashing	Battery undervoltage indication
	Putout	Stop output

6. MPPT Controller operation instruction

6.3 LCD Display Instruction

6.3.1 Main interface description

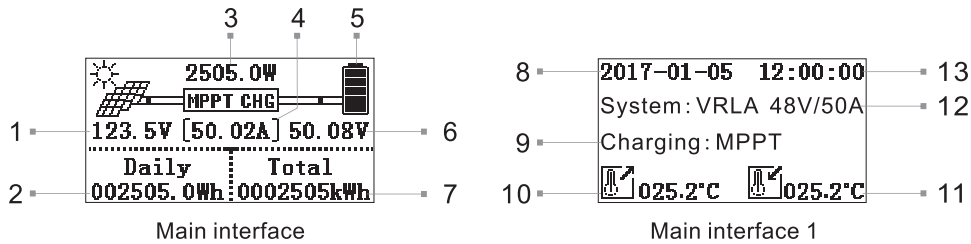

No	Decription	No	Decription
1	PV module voltage	8	Date
2	Daily power generation(charging volume)	9	Charging state:maximum power tracking, floating charge,stop charging.
3	Charging power	10	External temperature
4	Charging current	11	Internal temperature
5	Battery capacity indication	12	Battery type/System voltage current level
6	Battery voltage	13	Real time
7	Total power generation(charging volume)		

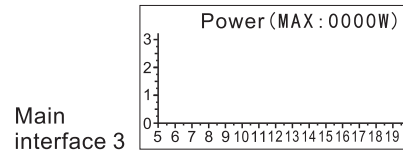
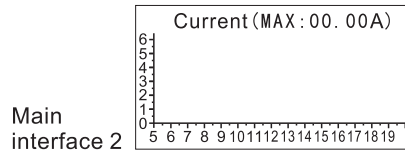

Name	Current Curve(Max:00.00A)	Name	Power Curve(Max:0000W)
X	Time (5:00-20:00)	X	Time (5:00-20:00)
Y	Current (Proportion:1:10)	Y	Power (Proportion:1:1000)
Max:00.00A(Record the highest charging current value of the day)		Max:0000W(Record the highest charging power value of the day)	

6.3.2 Check main interface

In the default main interface,press DOWN or UP to look through other interfaces.

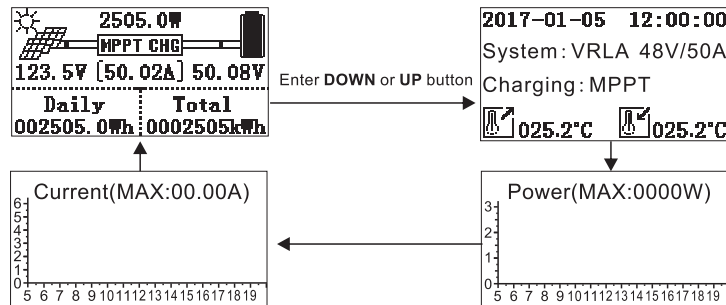

6. MPPT Controller operation instruction

6.3.3 Main menu

In the default main interface,press **MENU** to enter the main menu and press **DOWN** or **UP** to view the submenu.

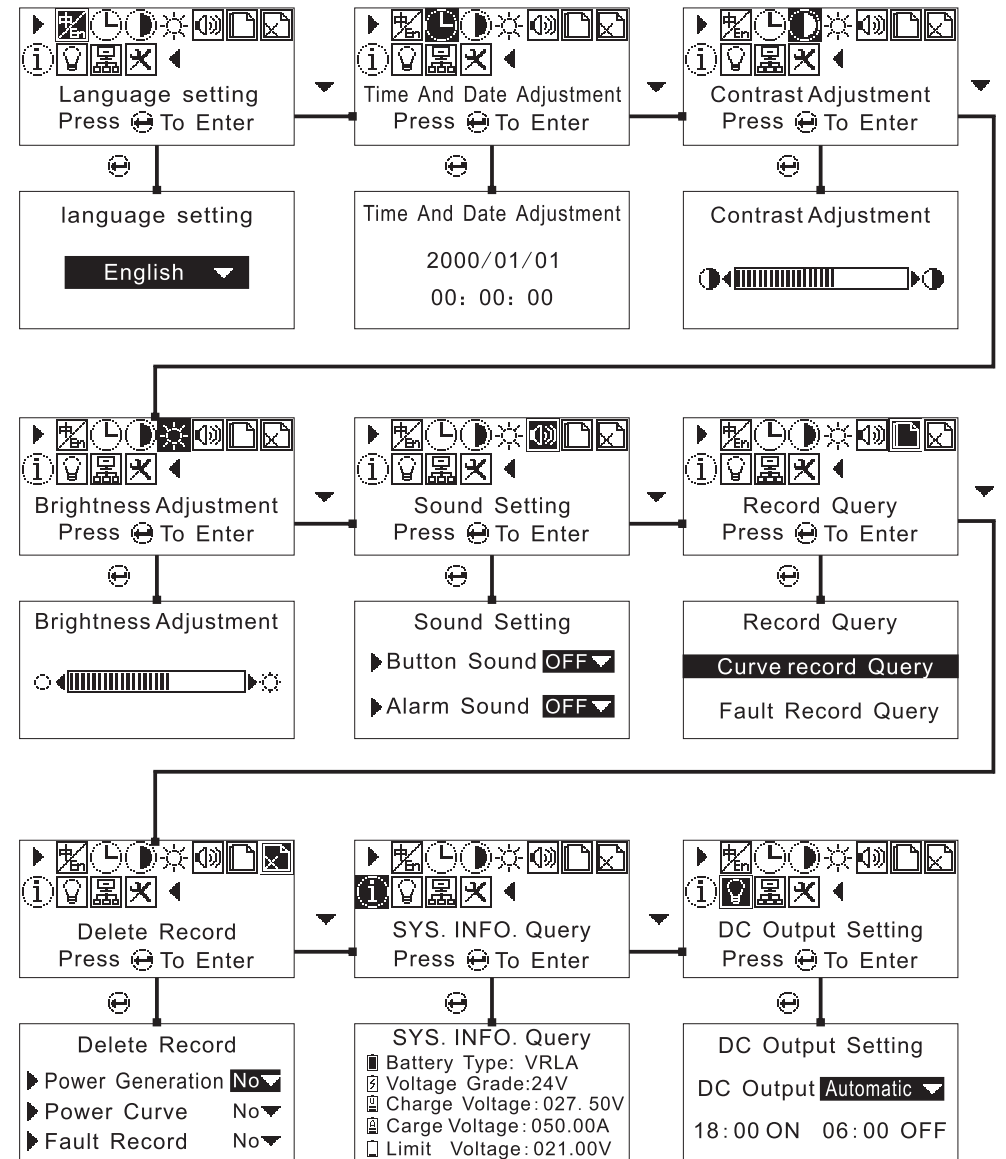

6. MPPT Controller operation instruction

6.3.3 Main menu

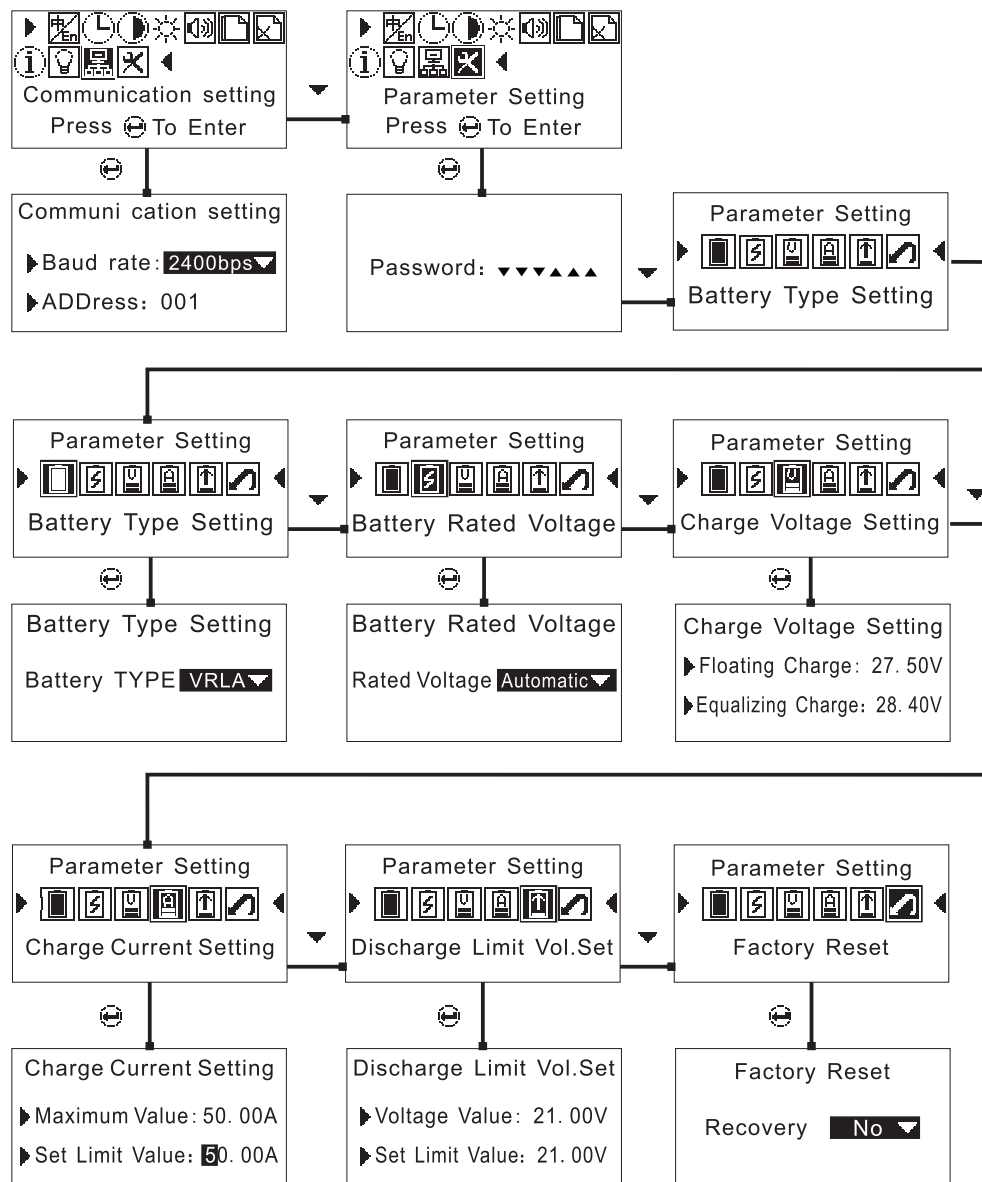

6. MPPT Controller operation instruction

6.4 Parameter setting

6.4.1 Language setting

In the default main interface, press **MENU** to enter the main menu, press **ENTER** to enter the language setting, press **DOWN** to select the language and then press the **ENTER** key to confirm and press **MENU** to return to the main interface after hearing continuous indicative sound.

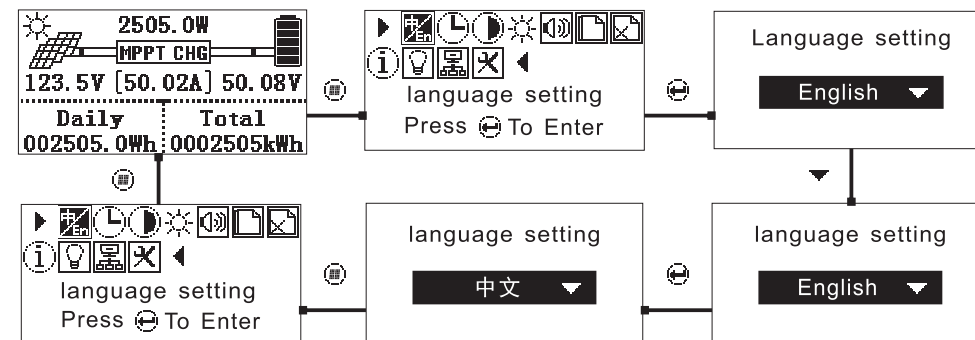

6.4.2 Time and date setting

In the default main interface, press **MENU** to enter the main menu, press **DOWN** to select the time setting, press **ENTER** to enter time setting, press **UP** to move the cursor, press **DOWN** to modify the value, press **ENTER** after confirming the modified value and press **MENU** to return to the main interface after hearing continuous indicative sound.

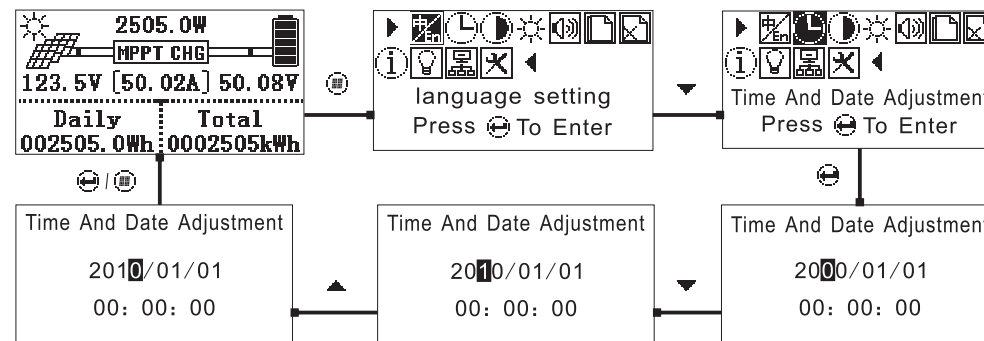

6.4.3 Contrast setting

In the default main interface, press **MENU** to enter the main menu, press **DOWN** to select the contrast setting, press **ENTER** to enter the contrast setting, press **DOWN** to reduce the contrast, press **UP** to increase the contrast, press **ENTER** to confirm and press **MENU** to return to the upper menu and the main interface after hearing continuous indicative sound.

6. MPPT Controller operation instruction

6.4.3 Contrast setting

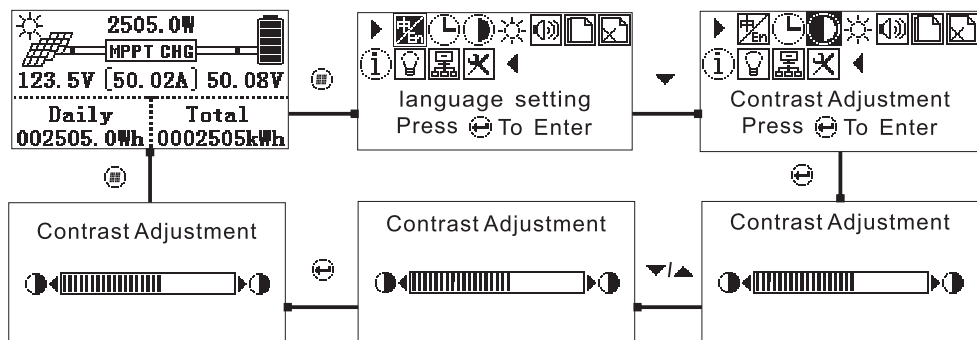

6.4.4 Brightness setting

The operations of brightness setting are the same with contrast setting.

6.4.5 Sound setting

In the default main interface, press **MENU** to enter the main menu, press **DOWN** to select the sound setting, press **ENTER** to enter the sound setting, press **DOWN** to select whether the key sound is on or off, press **UP** to move the cursor to select whether the alarm sound is on or off, press **ENTER** to confirm and press **MENU** to return to the main interface after hearing continuous indicative sound.

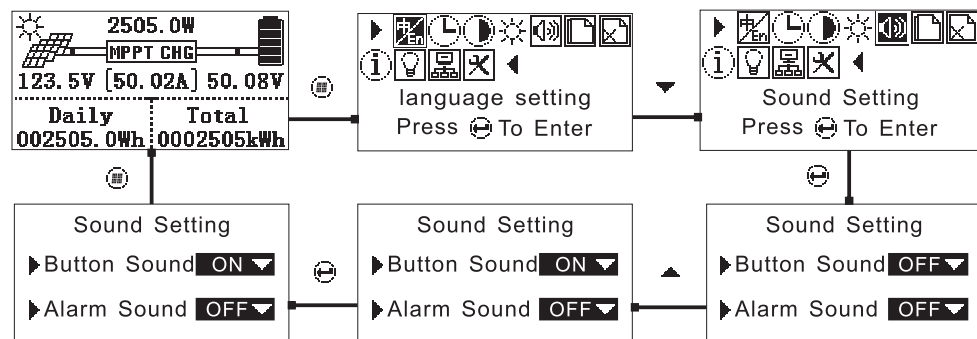

6.4.6 Record query

In the default main interface, press **MENU** to enter the main menu, press **DOWN** to select record query, press **ENTER** to enter record query, press **DOWN** or **UP** to select the curve record query or fault record query, press **ENTER** to enter the curve record query or fault record query, press **DOWN** or **UP** to check the record and there are 10 records totally. Press **MENU** to return to the upper and main interface.

6. MPPT Controller operation instruction

6.4.6 Record query

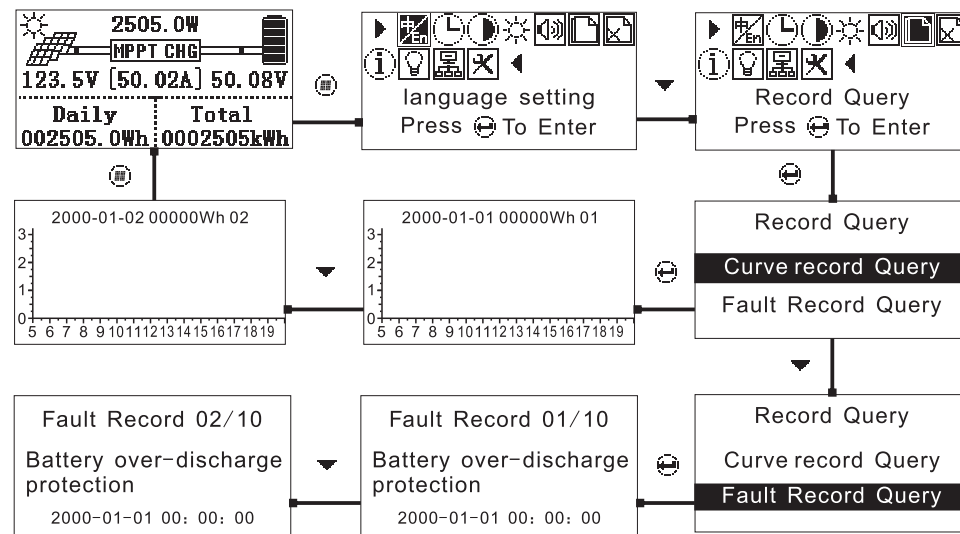

6.4.7 Delete record

In the default main interface, press **MENU** to enter the main menu, press **DOWN** to select the delete record, press **ENTER** to enter the delete record, press **UP** to move the cursor, press **DOWN** to select whether to delete, press **ENTER** to delete after selecting and press **MENU** to return to the upper menu and main interface after hearing continuous indicative sound.

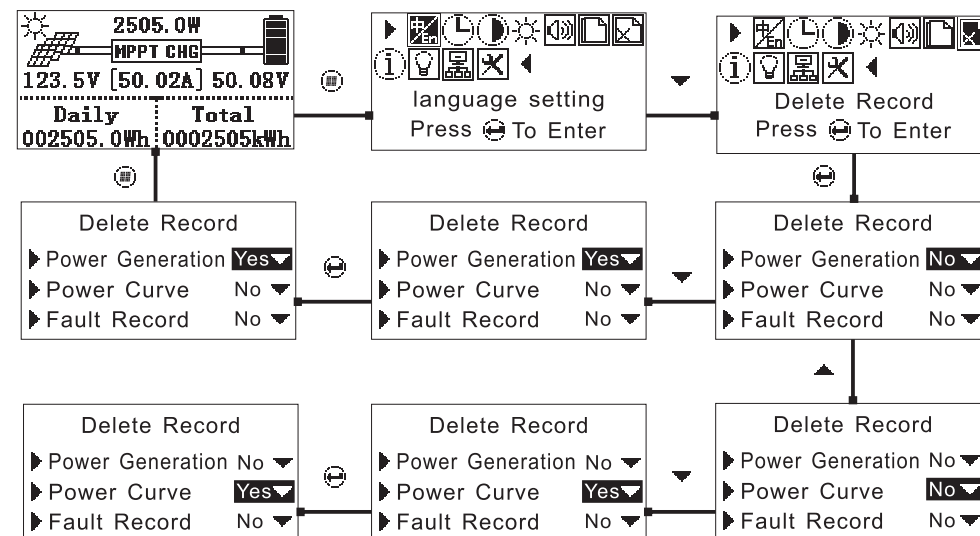

6. MPPT Controller operation instruction

6.4.8 System information query

In the default main interface, press **MENU** to enter the main menu, press **DOWN** to select the system information, press **ENTER** to enter the system information, press **MENU** to return to the main interface.

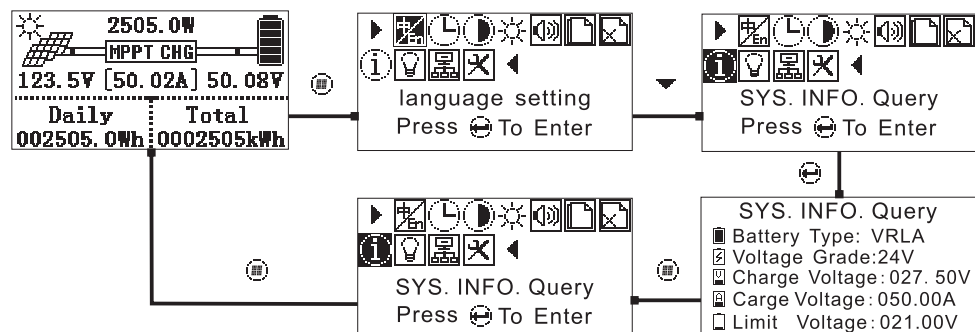

6.4.9 DC output setting

In the default main interface, press **MENU** to enter the main menu, press **DOWN** to select the DC output setting, press **ENTER** to enter the DC output setting, press **DOWN** to select OFF, Automatic and Time Control. When selecting OFF or Automatic, press **ENTER**. When selecting Time Control, please set the time period of opening and closing DC Output. Press **DOWN** to select Time Control and press **UP** to move the cursor. Press **DOWN** to input time value. Press **ENTER** to confirm and press **MENU** to return to upper menu and main interface after hearing continuous indicative sound.

Note: The key OFF refers to directly turn off the DC output. Automatic refers to turn on the DC output after the MPPT controller connects battery. Except battery undervoltage, Time Control refers to turn on or off the DC output according to the time period set.

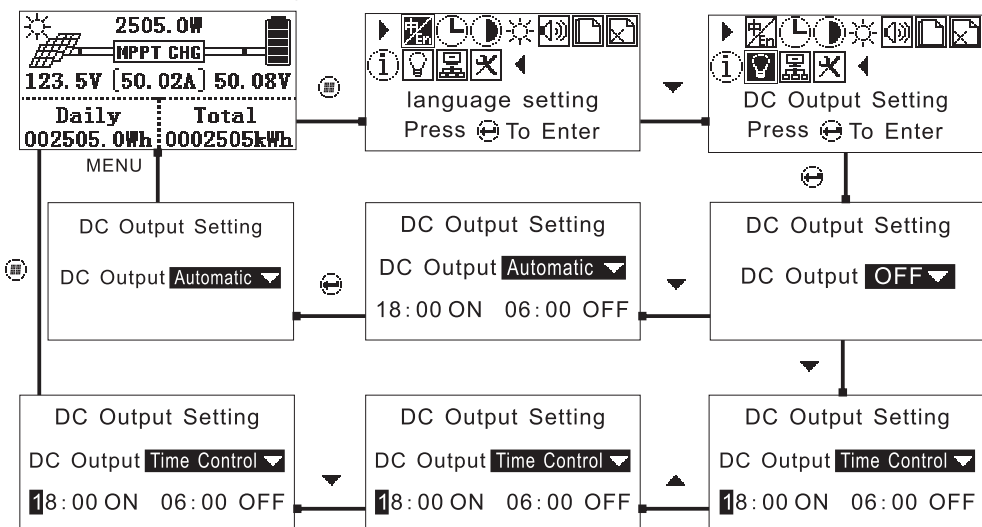

6. MPPT Controller operation instruction

6.4.10 Correspondence setting

In the default main interface, press **MENU** to enter the main menu, press **DOWN** to select the correspondence setting, press **ENTER** to enter the correspondence setting, press **UP** to select the baud rate setting or the local address setting, press **DOWN** to set Baud rate and the local address value, press **ENTER** to confirm and press **MENU** to return to the upper menu and main interface after hearing continuous indicative sound.

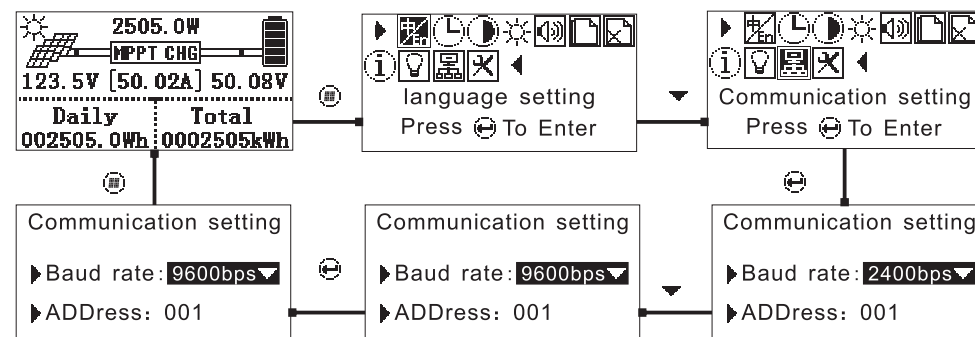

6.4.11 Operating parameter setting



Note: The operating parameter setting must be operated by qualified technicians. The MPPT controller will not work or suffer from damage of battery due to wrong operation.

In the default main interface, press **MENU** to enter the main menu, press **DOWN** to select the operating parameter setting, press **ENTER** to enter the password prompt interface, enter the password and then press **ENTER** to enter the operating parameter setting.

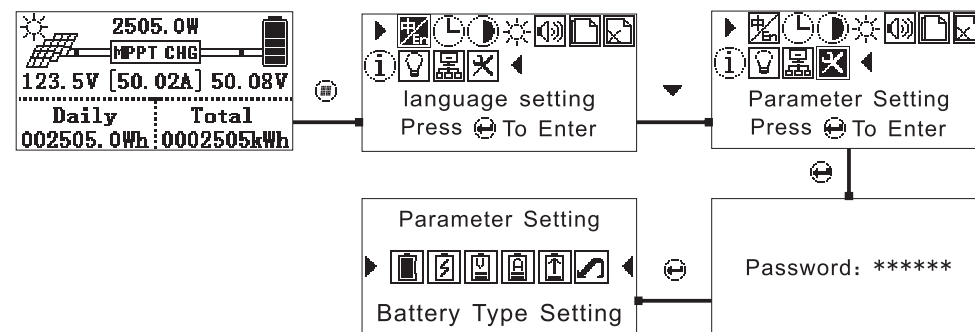

Note: Before setting the operating parameters, you must disconnect the circuit breaker which connects the PV module with the MPPT controller, set 5 parameters: battery type, rated voltage setting, charging voltage setting, charging current setting, discharging lower limit setting, check if parameters displayed on the system information are corresponding and then turned on the PV module circuit breaker.

6. MPPT Controller operation instruction

6.4.11.1 Battery type setting

In the operating parameters interface, press **ENTER** to enter the battery type setting, press **DOWN** to select battery type (Maintenance-free lead acid battery, colloidal battery, liquid battery, lithium series battery), press **ENTER** to confirm and press **MENU** to return to upper menu after hearing continuous indicative sound.

i Factory setting defaults to maintenance-free lead acid.

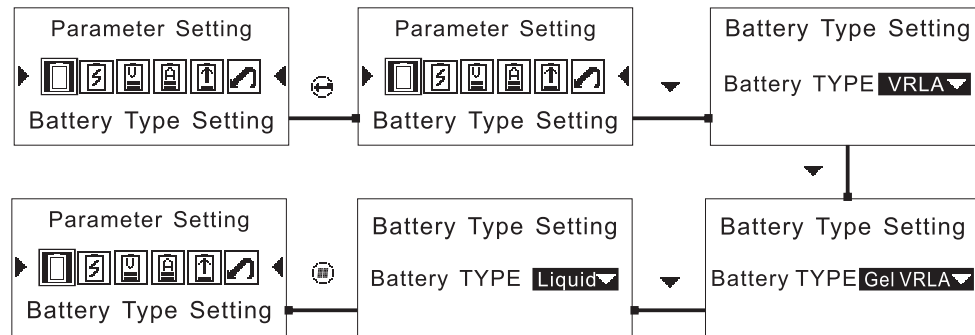

6.4.11.2 Battery rated voltage setting

In the operating parameters interface, press **DOWN** to select rated voltage setting, press **ENTER** to enter rated voltage setting interface, press **DOWN** to select voltage level (Automatically identify, 12V, 24V, 36V, 48V), press **ENTER** to confirm and press **MENU** to return to upper menu after hearing continuous indicative sound.

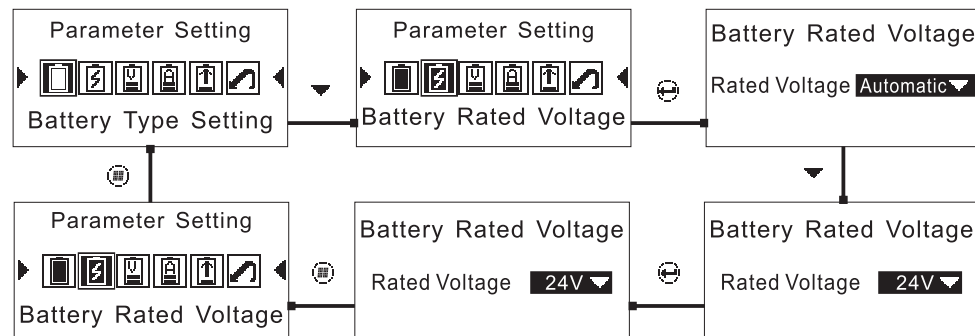

i Factory setting defaults to automatically identify the level of rated voltage which can only identify lead acid battery but lithium series battery are not included. When automatically identify the level of rated voltage, charging voltage and discharging lower limit voltage setting are not available. Charging voltage and discharging lower limit voltage setting are only available for manual setting.

6. MPPT Controller operation instruction

6.4.11.3 Charging voltage setting

In the operating parameters interface, press **DOWN** to select charging voltage setting, press **ENTER** to enter rated voltage setting interface, press **UP** to move cursor, press **DOWN** to input numeral, press **ENTER** to confirm and save and press **MENU** to return to upper menu after hearing continuous indicative sound.

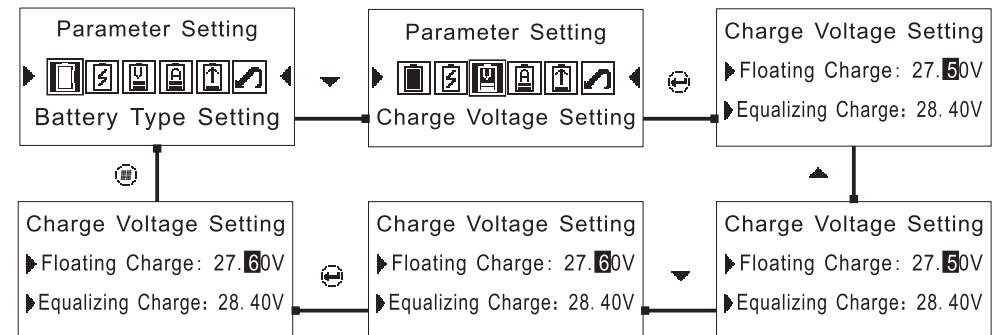

i Lithium battery series only have float (constant voltage) charging mode. Equalized charging mode can be only used for lead acid battery.

6.4.11.4 Charging current setting

In the operating parameters interface, press **DOWN** to select charging current setting, press **ENTER** to enter charging current setting interface, press **UP** to move cursor, press **DOWN** to input value, press **ENTER** to confirm and save and press **MENU** to return to upper menu after hearing continuous indicative sound.

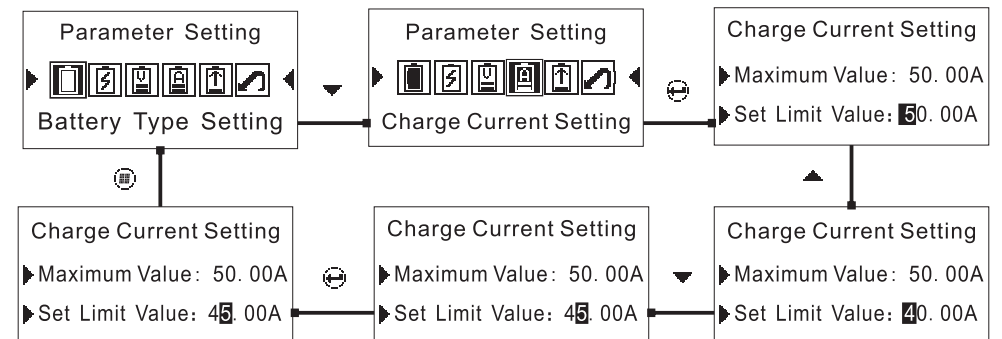

i The set point can not be greater than the current maximum.

6. MPPT Controller operation instruction

6.4.11.5 Discharging limitation setting

In the operating parameters interface, press **DOWN** to select discharging limitation setting, press **ENTER** to enter discharging limitation setting interface, press **UP** to move cursor, press **DOWN** to input value, press **ENTER** to confirm and save and press **MENU** to return to upper menu after hearing continuous indicative sound.

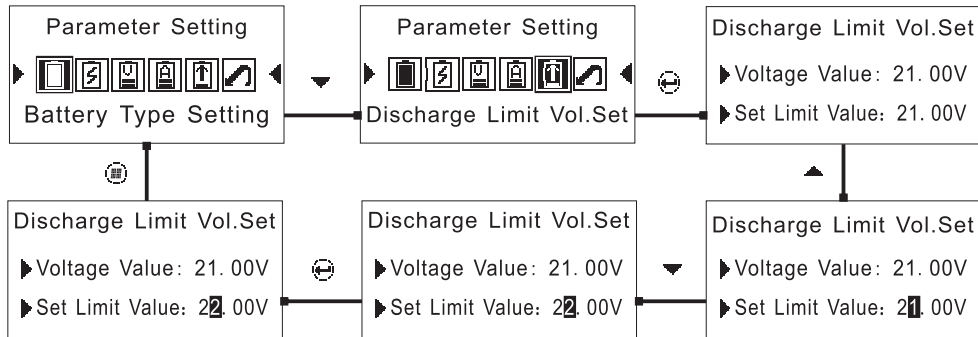

6.4.11.6 Restore factory setting

In the operating parameters interface, press **DOWN** to select factory reset, press **ENTER** to enter factory reset interface, press **DOWN** to select whether to restore factory setting, press **ENTER** to confirm and save and press **MENU** to return to upper menu after hearing continuous indicative sound.

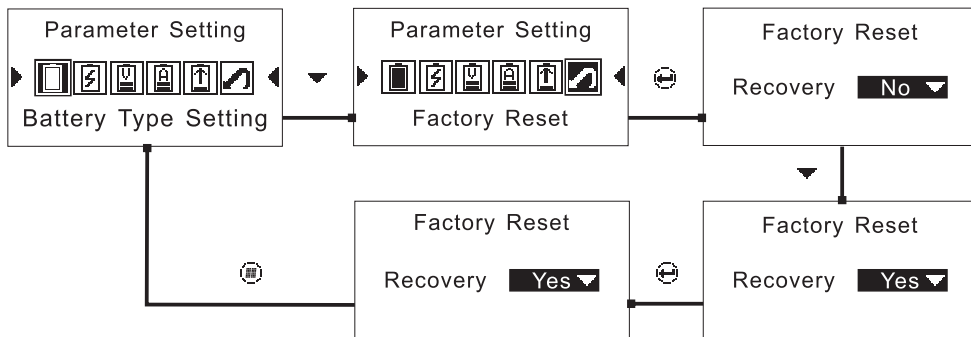

i When MPPT solar controller can not operate normally due to fault of operating parameter setting, please restore the operating parameters to factory setting.

6.4.11.7 Code

Press **DOWN** for 3 times and then **UP** for 3 times and press **ENTER** to enter operating parameters setting interface.

7. Technical parameter

Model : 50A/60A/80A/ 100A/120A Series	50A	60A	80A	100A	120A
Charging mode	MPPT automatic maximum power point tracking				
Charging method	Three stages: Constant current charging(MPPT), Equalizing charging, float charging				
System Type	12V/24V 36V/48V/96V	Automatical recognition / Manual setting			
System identification voltage range	12V System	DC9V-DC15V			
	24V System	DC18V-DC30V			
	36V System	DC27V-DC45V			
	48V System	DC36V-DC60V			
	96V System	DC80V-DC120V			
Quiescent dissipation	12V/24V 36V/48V/96V	≤2W			
Overall Unit efficiency	12V/24V 36V/48V/96V	≥96.5%			
Photovoltaic module utilization ratio	12V/24V 36V/48V/96V	≤99%			
Input Characteristics					
MPPT Working voltage range	12V System	DC18V-DC80V			
	24V System	DC30V-DC100V			
	36V System	DC40V-DC100V			
	48V System	DC65V-DC150V			
	96V System	DC120V-DC200V			

7. Technical parameter

Maximum solar input power	12V System	700W	900W	1100W	1400W	1800W
	24V System	1400W	1700W	2200W	2800W	3400W
	36V System	2100W	2700W	3600W	4200W	5400W
	48V System	2800W	3400W	4500W	5600W	6800W
	96V System	5600W	7200W	9000W	11200W	14400W
Output Characteristics						
Optional battery type (default lead-acid-free maintenance-free battery)	12V/24V 36V/48V/96V	Sealed lead acid, Gel, NiCd battery or User-Defined)				
Floating charging voltage (lead acid battery)	12V System	13.8V(Customizable floating charge voltage)				
	24V System	27.6V(Customizable floating charge voltage)				
	36V System	41.4V(Customizable floating charge voltage)				
	48V System	55.2V(Customizable floating charge voltage)				
	96V System	110.4V(Customizable floating charge voltage)				
Average charge voltage (lead acid battery)	12V System	14.4V(Customizable floating charge voltage)				
	24V System	28.8V(Customizable floating charge voltage)				
	36V System	43.2V(Customizable floating charge voltage)				
	48V System	57.6V(Customizable floating charge voltage)				
	96V System	115.2V(Customizable floating charge voltage)				
Rated current	12V/24V 36V/48V/96V	50A	60A	80A	100A	120A
Current-limiting protection	12V/24V 36V/48V/96V	52A	62A	82A	102A	122A
Temperature coefficient	12V/24V 36V/48V/96V	$\pm 0.02\%/^{\circ}\text{C}$				
Auto temperature compensation	12V/24V 36V/48V/96V	$-4\text{mV}^{\circ}\text{C}$				

7. Technical parameter

Model : 50A/60A/80A/ 100A/120A Series	50A	60A	80A	100A	120A
Display					
LCD Display	LCD panel indicating solar power, load level, battery voltage/capacity, charging current, and fault conditions				
LED Display	DC output indication				
PC Uppon Computer (Communication port)	RS-485				
Protection					
Input low voltage protection	Reference input attribute				
Input high voltage protection	Reference input attribute				
Input polarity reverse protection	yes				
Output polarity reverse protection	yes				
short-circuit protection	Could be short-circuited for a long time, could be recovered after the short-circuit fault is eliminated				
High temperature protection	90 degrees Celsius				
Audible noise	$\leq 45\text{dB}$				
Heat dissipation mode	Intelligent air cooling				
Product specification package					
Product Size (L*W*H) mm	230x279x91	230x304x91	303x436x138		
Net Weight (kg)	3.2	3.4	10.5		
Type of mechanical protection	IP32				

7. Technical parameter

Environmental requirements	
Humidity	0~90%RH (No Dew)
Height above sea level	0~3500m
Ambient temperature	-20°C~+60°C
storage temperature	-40°C~+70°C
Photovoltaic module configuration	
System voltage (battery voltage)	Photovoltaic module load voltage (recommended data)
12V System	18V~60V
24V System	36V~72V
36V System	54V~144V
48V System	72V~144V
96V System	120V~200V

7. Technical parameter

Photovoltaic power-Conversion efficiency curve

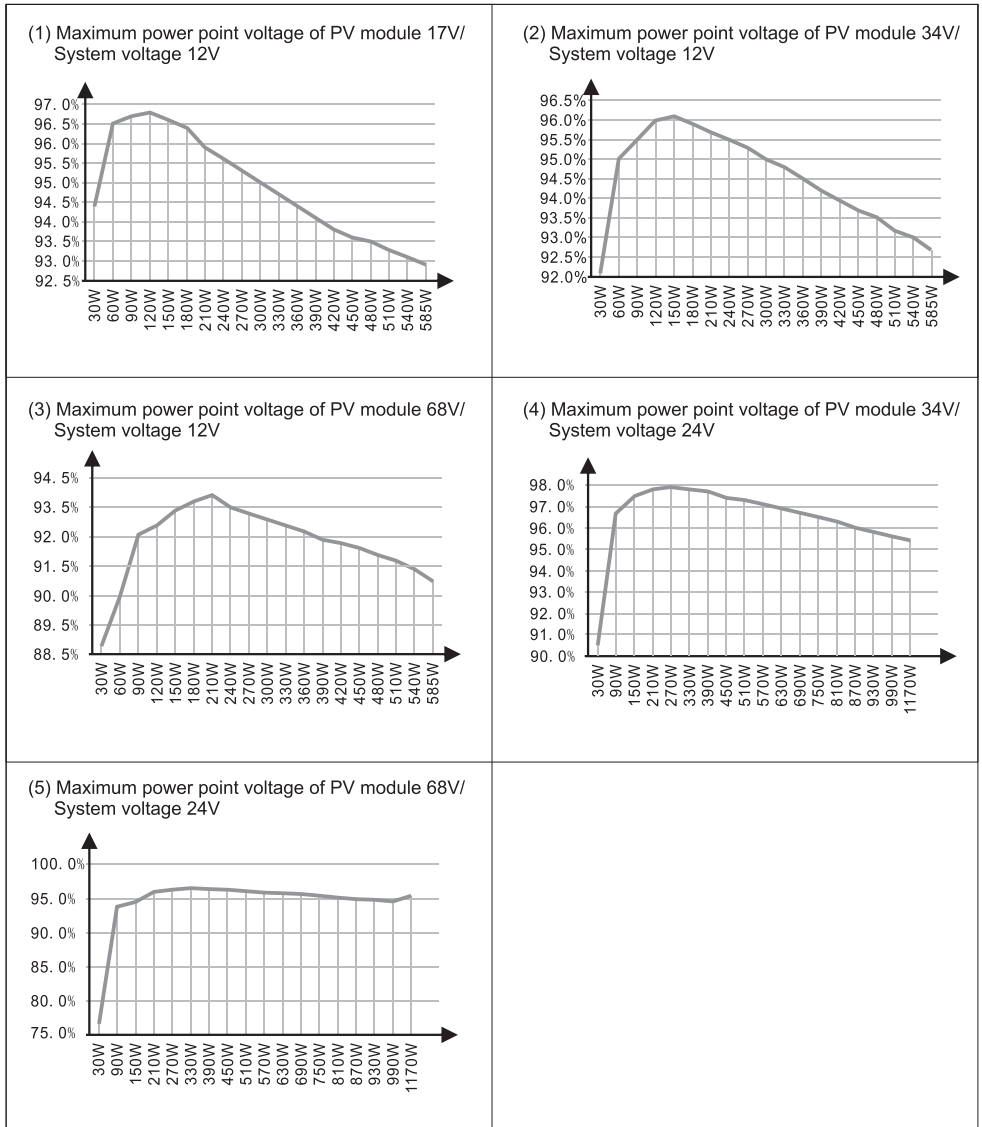

8. Maintenance & Cleaning

8.1 Fuse replacement

Fuse blown due to excessively high temperature or other faults needs correct replacement: pull out the broken fuse from the joint, install new fuse, check if it is connected correctly and then install equipment.(Fuse is near the connecting box)

8.2 Clean fan vent & heat sink

Please regularly clean fan vent and internal heat sink with dry or slightly wet cloth. Please pay attention that washing liquid or corrosive solvent are banned for cleaning and liquid is not allowed to flow into machine to make sure that the air vents are not blocked.

9. Fault elimination

When the controller works abnormally, please check conditions listed as below

Fault situation	Fault elimination
When controller is electrified for the first time, fault prompts: battery voltage is out of normal range	<ol style="list-style-type: none"> 1. Check whether the battery voltage is in the range of system voltage identification (See technical parameters for system voltage identification range) 2. Manually set rated battery voltage level (See the rated battery voltage setting in the operating parameters setting)
Fault indication: over temperature protection	<ol style="list-style-type: none"> 1. Check whether the cooling fan is damaged and ventilation vents are blocked by debris; MPPT controller should be installed in a ventilated environment 2. Reasonable PV module configuration can improve conversion efficiency and reduce temperature rise (technical parameters PV module configuration)
Fault indication: battery over discharging protection	The battery is out of power
Fault indication: can not test external temperature sensor	<ol style="list-style-type: none"> 1 Check whether it is connected to the external temperature sensor 2 check whether the sensor contact is bad
Charging indicative light and displays of charging current and charging power are off and on	<ol style="list-style-type: none"> 1 Check whether PV module voltage is in the MPPT operating voltage range. 2 Check whether the charging voltage parameters shown on system are correct. 3 Correct the charging voltage parameters or restore the factory settings to restart dynamic MPPT controller. 4 Check whether the fuse is broken and the circuit breaker is disconnected.
Charging indicative light is off and on alternatively; charging current appears alternatively	This situation generally appears in cloudy day or evening when the light is insufficient which is a normal phenomenon
No power curve and current curve display	Check whether the time and date of the MPPT controller are consistent with the time you are in. (see time and date set)

If the problem is still on the table, please contact customer service personnel : Please provide the following information: equipment: type, order number, serial number (the label on the back plate); a detailed description of the problem (such as the use of the type system, problems occurred occasionally or frequently, indicating light, display etc.).

10. Quality assurance

During the warranty period, our company will repair for free or replace with new products

Evidence

In the quality assurance period, our company requires customers to provide invoices and date of purchased products.

At the same time the trademark on the product should be clearly visible, otherwise we have the right not to guarantee quality.

Condition

- The rejected products shall be disposed of by our company
- The customer shall allow reasonable time to repair the faulty equipment

Exemption from liability

In the following cases, our company will be not responsible for repair:

- The whole machine or spare parts are beyond the warranty period
- Transport damage
- Incorrect installation or modification
- Operating in a very harsh environment described beyond this manual
- Failure or damage to the machine caused by the service, repair, alteration or removal of our company
- Abnormal natural environmental damage

If customers ask for amendment service due to problems caused by faults listed above, our company can provide compensable amendment service after judgment of our service constitute.

Note

The charge of product size and parameter is subject to the newest materials of our company without further notice.